

650nm, Small Size, Standard Model,

**Application:**

Industrial areas

**Property:**

Wavelength Range = 650nm (others optional)

**Introduction:**

Egismos created compact laser series that have very attractive price tag. Our standard modules are emitting 635nm and 650nm red wavelengths, however custom wavelength are also available. Other characteristics like TTL or custom optics is also available upon a request.

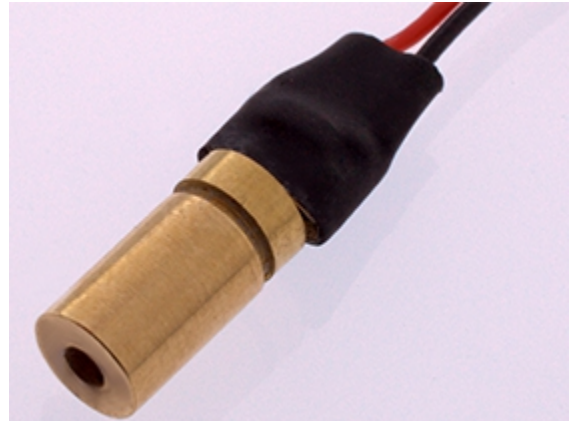

**Specifications:**

Specifications(T=25°C)	Symbol	S636501D/R S636505D/R	H636501D/R H636505D/R
Mode		CW	CW
Wavelength	$\lambda$	650nm	650nm
Spot		Dot	Dot/Round
Spot Size		<8x 12mm at 10m	<10mm round at 10m min. <8mm at 10m
Diameter x Length	$\Phi \times l$	6x12mm	6x12mm
Output Power	$P_o$	<1mW, <5mW	0.9mW $\pm$ 10%, 3.2mW $\pm$ 10%, min<5%
Power Stability		<10%	<2%(PCB inside <5%)
Divergence Angle	mrad	<1	<0.2, min<0.1
Operating Voltage(DC)	$V_o$	2.6V~6.0V	2.6V~6.0V
CW Operating Current	$I_o$	25~35mA 50mA max	25~35mA 50mA max
Operating Temperature	$T_o$	-10°C ~ + 50 °C	-10°C ~ + 70 °C or higher max to +90°C
Storage Temperature	$T_s$	-40 °C ~ + 85 °C	-40 °C ~ + 120 °C
Boresight	deg	-	~ 3 degree
Housing Material		Brass/Aluminum	Brass/Aluminum
Mean time to failure(MTTF)		4,000~6,000	6,000~8,000

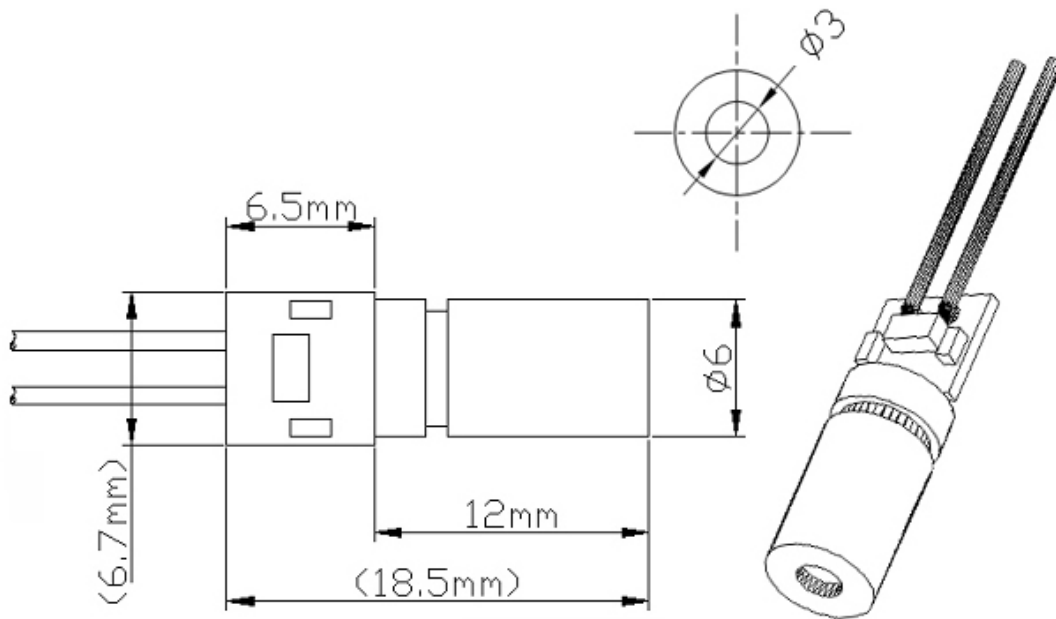
**Outline Dimensions:****Certification:****FDA****CE****Laser Safety**

The light emitted from these devices has been set in accordance with IEC60825. However, staring into the beam, whether directly or indirectly, must be avoided.

**Class I**

The maximum permissible exposure (MPE) cannot be exceeded, it includes High-power lasers within an enclosure that prevents exposure to the radiation and that cannot be opened without shutting down the laser. For example, a continuous laser at 600nm can emit up to 0.39mW, but for shorter wavelengths, the maximum emission is lower.

**Class II**

"Caution", visible laser light less than 1.0mW. Considered eye safe, normal exposure to this type of beam will not cause permanent damage to the retina.

**Class IIIA**

"Danger", visible laser light between 1.0mW and 5.0mW. Considered eye safe with caution. Focusing of this light into the eye could cause some damage.

**Class IIIB**

"Danger", infrared (IR), and high power visible lasers considered dangerous to the retina if exposed. NB: it is important to note that while complying with the above classifications, unless otherwise stated. Our laser diode products are not certified and are designed solely for use in OEM products. The way in which device is used in the final product may alter its original design classification, and it is the responsibility of the OEM to ensure compliance with the relevant standards.